

N 96 SERIES VACUUM PUMPS AND COMPRESSORS



N 96 KNDC-B-M

ADVANTAGES

- Copes well with vapor and condensation
- The pump can start against the entire pressure and vacuum range without discharging
- Brushless DC motor for custom-fit rotational speed control
- Low operating costs and reduced heat emissions from the pump thanks to efficient motor
- Extended temperature range for ambient temperatures up to 50 °C and media temperatures up to 70 °C
- High level of gas tightness: 6×10^{-3} mbar x l/s according to type examination

POSSIBLE AREAS OF USE

- Stationary emission measurement technology
- Mobile/portable gas measurement technology
- Instrumental analysis
- Medical technology – especially diagnostics

Please visit our website
www.knf.com
to get more information

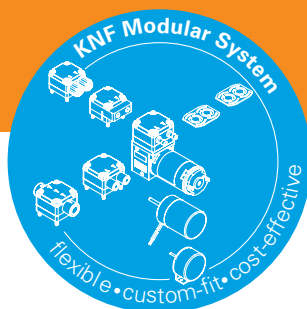

PERFORMANCE DATA

Series model	N 96	
Material design	KTDC-B-M	KNDC-B-M
Pump head	PPS	
Diaphragm	PTFE-coated	EPDM
Valves	FKM	
Flow rate at atm. pressure (l/min)	7.0 ± 10 %	8.5 ± 10 %
Ultimate vacuum (mbar abs.)	< 130	
Max. operating pressure (bar rel./psig)	2.5/36.3	
Permissible ambient temperature (°C)	+5 ... +50 (> 2 bar rel.: +5 ... +40) 0 if frost-free (non-condensing)	
Permissible media temperature (°C)	0 ... +70	0 ... +50
Weight (kg/lbs)	0.6/1.3	

ELECTRICAL DATA

Voltage (V)	24	
Motor	Brushless DC motor, PWM-signal: 55...0 %	Brushless DC motor, PWM-signal: 30...0 %
Protection class motor	IP 20	
Power P_1 (W)	19	23
I_N (A)	0.9	1.05

N 96 KTDC-B-M

PERFORMANCE DATA

Series model	Flow rate at atm. pressure (l/min) ¹⁾	Max. operating pressure (bar rel./psig)	Ultimate vacuum (mbar abs.)
N 96 KTDC-B-M	7.0 ± 10 %	2.5/36.3	< 130

¹⁾ Liter at STP

N 96 KTDC-B-M

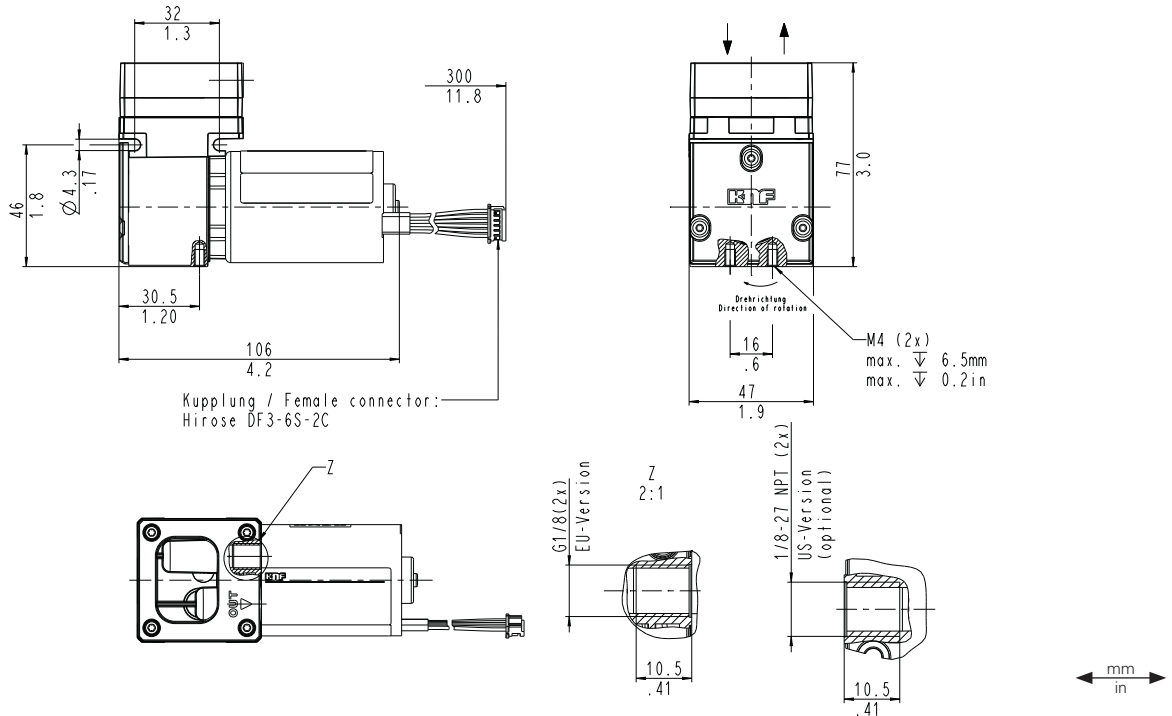

N 96 KTDC-B-M

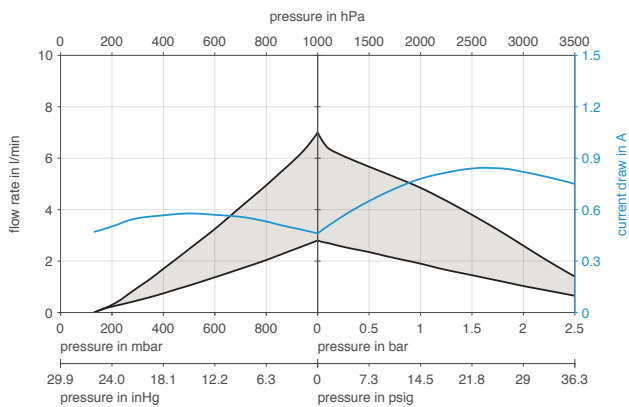

N 96 KTDC-B-M | PUMP UP TIME FOR 5 LITER VESSEL

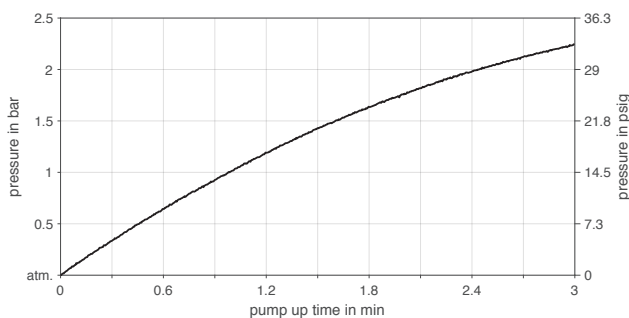

N 96 KTDC-B-M | PUMP DOWN TIME FOR 5 LITER VESSEL

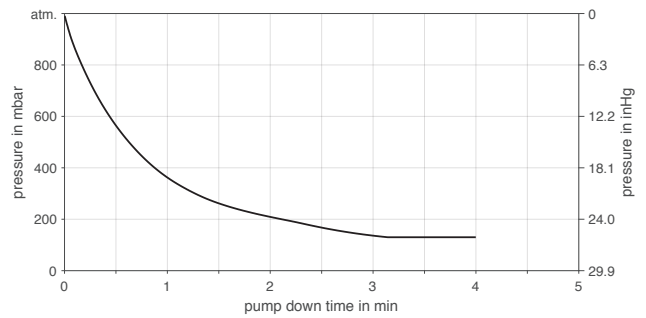

N 96 KNDC-B-M

PERFORMANCE DATA

Series model	Flow rate at atm. pressure (l/min) ¹⁾	Max. operating pressure (bar rel./psig)	Ultimate vacuum (mbar abs.)
N 96 KNDC-B-M	8.5 ± 10 %	2.5/36.3	< 100

¹⁾ Liter at STP

N 96 KNDC-B-M

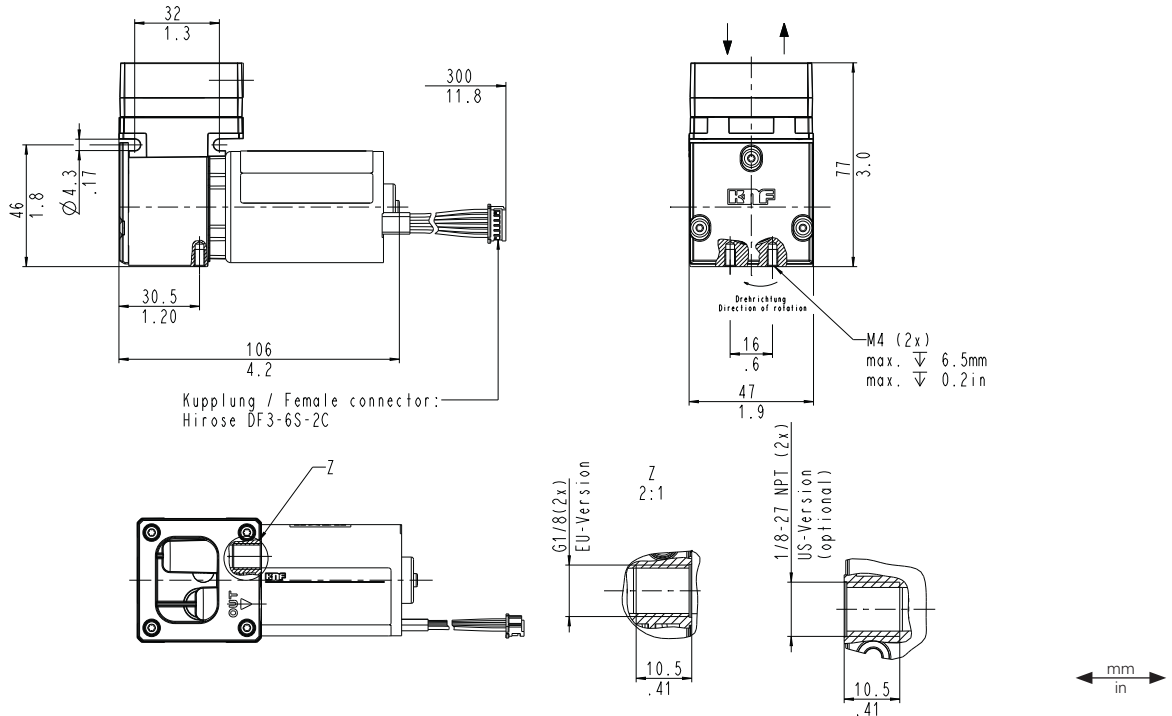

N 96 KNDC-B-M

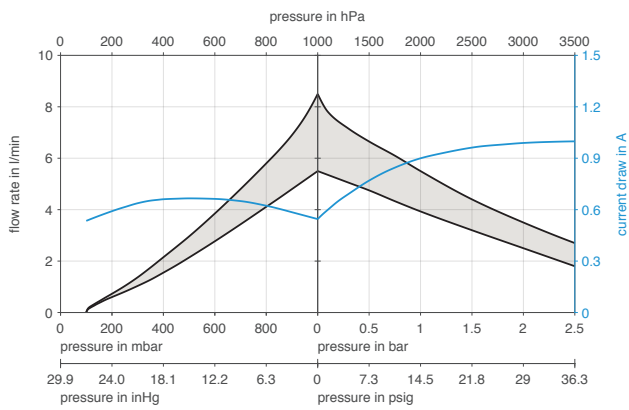

N 96 KNDC-B-M | PUMP UP TIME FOR 5 LITER VESSEL

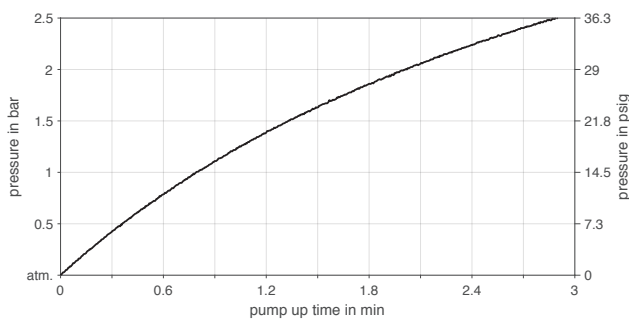

N 96 KNDC-B-M | PUMP DOWN TIME FOR 5 LITER VESSEL

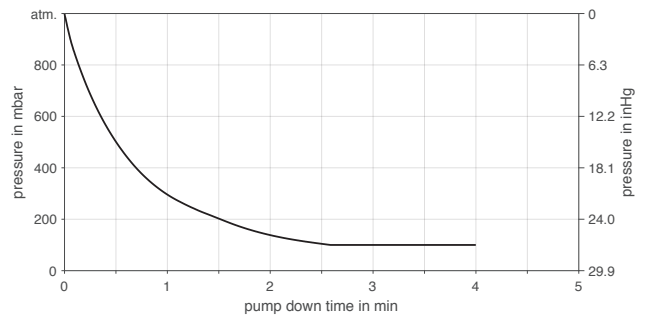

ACCESSORIES

Description	Illustration	Part No.	Details
Silencer		000345	
Inlet filter		000346	
Hose connector		001936	PA, ID 4
Hose connector		025671	PVDF, ID 4
Hose connector		020185	PA, ID 6
Hose connector		123363	PVDF, ID 6
Rubber bonded metal		320986	
Base plate		321256	

SPARE PARTS

Description	Part No.
Spare parts kit N 96 KTDC-B-M	322636
Spare parts kit N 96 KNDC-B-M	322637

The performance values for the series models shown on this data sheet were determined under test conditions. The actual performance values may differ and depend in particular on the usage conditions and therefore on the specific application, on the parameters of the components involved in the user's system and on any technical modifications carried out which deviate from the standard configuration or the as delivered condition.

If individual designs have been created for specific customers on the basis of series models, other technical performance data may apply. Before operation begins, the relevant operating instructions and/or assembly or installation instructions should be read and the safety information contained in these instructions should be noted. KNF reserves the right to make changes to the product and the associated documentation without prior notice to the customer.



www.knf.com