

# Application Note

**Date:** 16th May 2017

**From:** Test and Calibration Engineering Team

## Connecting DPI620G-IS to HART® Devices

This application note details the valid connection methods for using a DPI620G-IS as a HART® communicator with a HART® transmitter.

### 1 Active HART® Current Loop

In the example that follows, the calibrator connects directly to an existing network. There must be a 250Ω resistor in series with the loop power supply and the HART® device. When connecting in this mode the external series HART resistor cannot be replaced with the internal HART resistor.

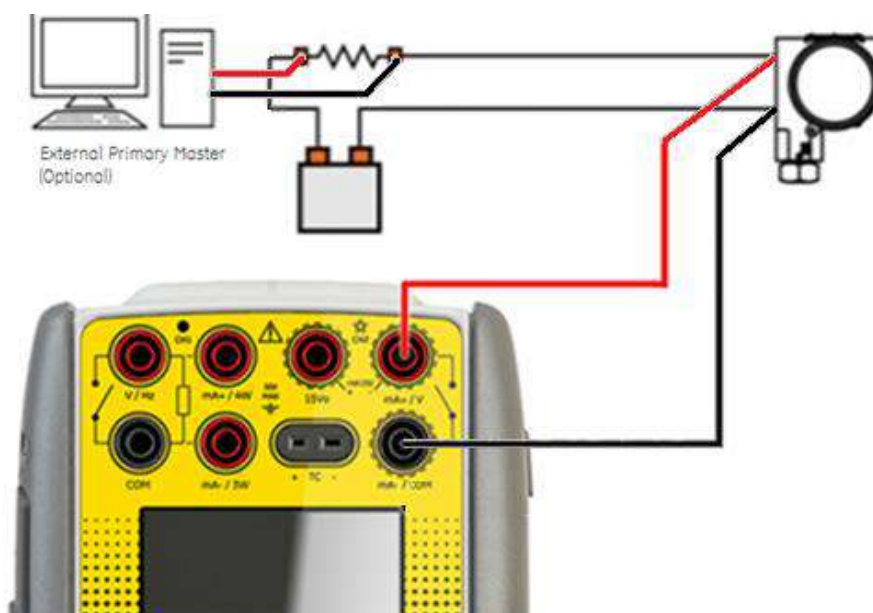

Figure 1-1 Connection to Active Current Loop

- CH2 function is set to None.
- HART® function is enabled and 250Ω resistor is set to Off.
- Internal Loop Power is turned off.
- Internal HART resistor should be turned off

The DPI620G-IS will either operate as a Primary Master, if no other Primary Master is fitted to the network or as a Secondary Master when connected into an already active HART® loop.

## 2 Transmitter - External Loop Supply with Current Measure

In the example that follows, an external power supply provides the loop power and the DPI620G-IS provides the 250Ω HART® resistor. When connecting in this mode with the DPI620G-IS measuring the current in the current loop, the internal HART resistor must be turned on to enable HART® communication. If an external HART resistor is present it is recommended to use the connection method (refer to Section 1) described for active HART® Current Loop.



Figure 2-1 Connection with External Loop Supply

Note: The user should consider the voltage drop due to the loop impedance in relation to the transmitter operating voltage. (The loop impedance is made up of the 250Ω HART resistor in series with the output impedance of the power supply).

### 3 Transmitter - Internal Loop Power Supply with Current Measure

In the example that follows, the DPI620G-IS supplies the loop power and a 250Ω HART resistor. When connecting in this mode, measuring the current in the current loop, the internal HART resistor must be turned on to enable HART® communication. If an external HART resistor is present it is recommended to use the connection method (refer to Section 1). described for active HART® Current Loop.



Figure 3-1 Connection with Internal Loop Supply

As the internal loop supply is intrinsically safe, it has an internal impedance of 100Ω, at high loop currents, the minimum voltage requirements of the transmitter may not be achieved when the 250Ω HART resistor is also included in the loop.

A diagrammatic representation of the loop is shown in Figure 3-2.

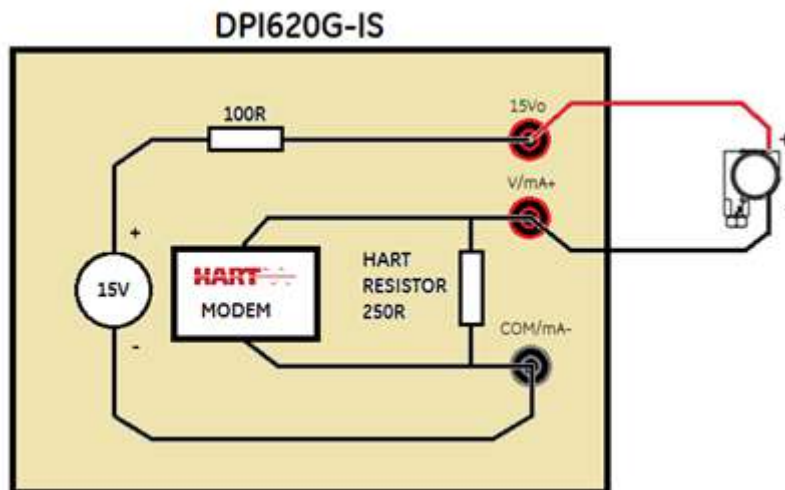

Figure 3-2 Internal Loop Supply Current Measure

For example: At a loop current of 15mA, the voltage drop will be  $15\text{mA} \times (100\Omega + 250\Omega) = 5.25\text{V}$ .

In this instance the voltage at the transmitter will be 9.75V.

The graph below shows the voltage that will be seen at the transmitter with (red line) and without (blue line) the HART® resistor present in the current loop. This assumes no significant additional impedance is present in the current loop.

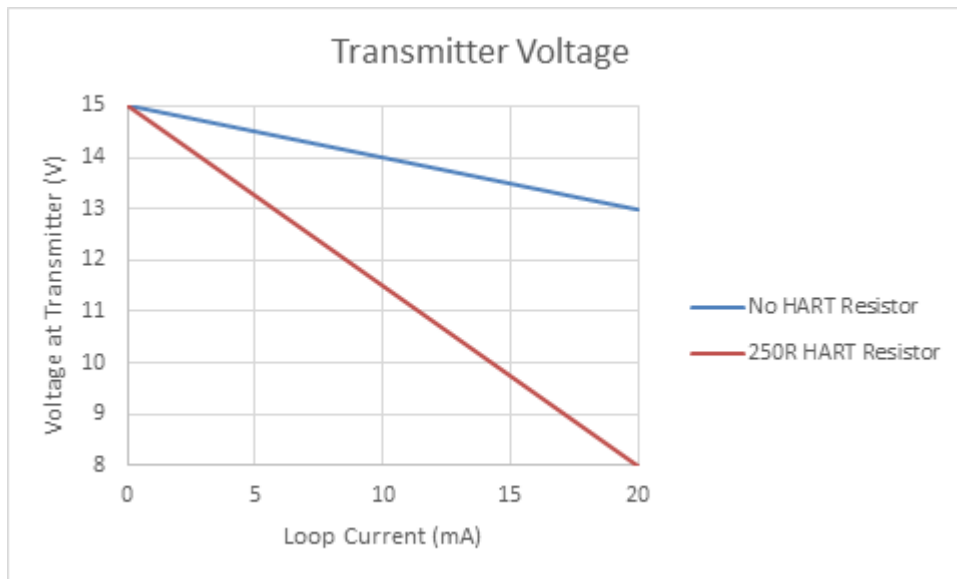

Figure 3-3 Transmitter Voltage

If the transmitter is expected to be used in circumstances where the loop current will reduce the voltage at the transmitter to below its minimum operating voltage, it is recommended to either use an external power supply (Refer to Section 2) or use a parallel HART® connection with the Internal Loop Supply (Refer to Section 4)

Note: When using an external power supply, the voltage drop due to the loop impedance (Power supply impedance + HART resistor) in relation to the transmitter operating voltage should still be considered.

## 4 Transmitter - Internal Loop Power Supply with Parallel HART® Connection

In the example that follows, the internal power supply provides the loop power and the loop impedance required for the HART® function is provided by the output impedance of the internal power supply (Refer to Note 1).

When connected in this mode it is not possible to measure the loop current using the Channel 2 terminals.

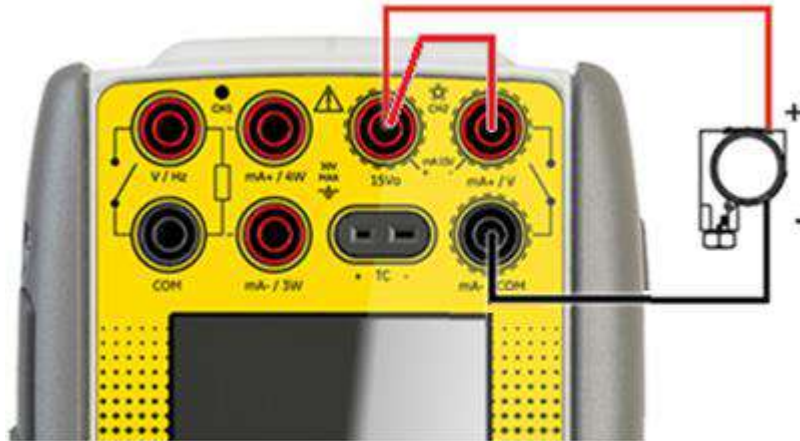

Figure 4-1 Connection with Internal Loop Supply, Parallel HART Connection

- CH2 function is set to None
- HART® function is enabled
- 250Ω resistor is Off
- Internal Loop Power is turned on through the Settings Menu for the HART® channel

A diagrammatic representation of the loop is shown in Figure 4-2.

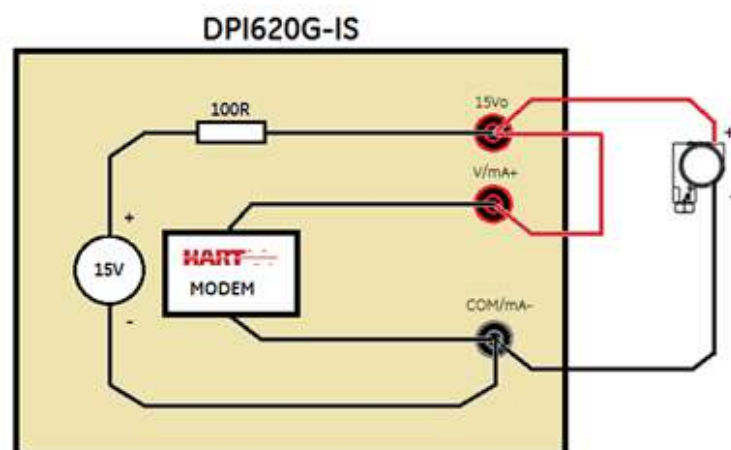

Figure 4-2 Internal Loop Supply parallel HART Connection

In this mode, the voltage drop due to loop impedance is minimised, and the voltage seen at the transmitter will be as per "No HART resistor" (blue line) plot in Figure 3-3.

Note 1: The DPI620G-IS is compliant with the HART® Physical Layer Test Specification when used with a 230Ω HART resistor. When the DPI620G-IS is connected directly to a transmitter that is also compliant with the HART® Physical Layer Test Specification using test leads of <3m length, the 100Ω output impedance of the internal loop supply will give a ratio of 1.45 between the minimum permitted transmit voltage levels and the minimum receive levels for the DPI620G-IS and the HART® transmitter.

## 4.1 Measuring Loop Current with Parallel HART® Connection

When connected with a parallel HART® connection it is not possible to measure current on Channel 2. To measure the loop current and/or perform a current loop trim it is necessary to utilise the Channel 1 current measure function.

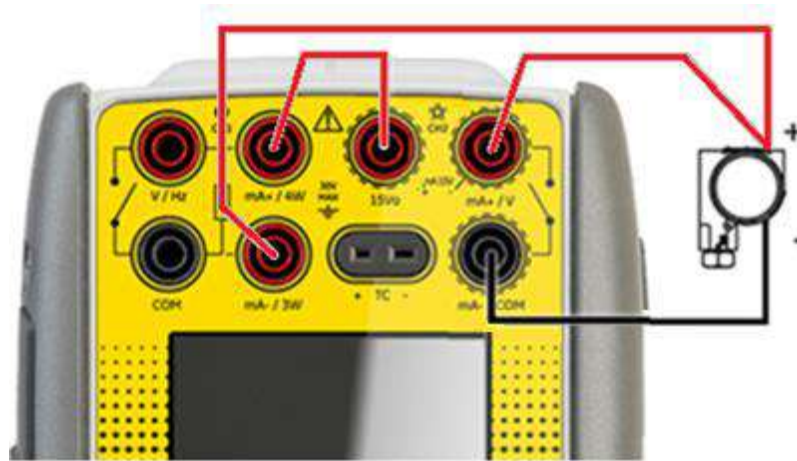
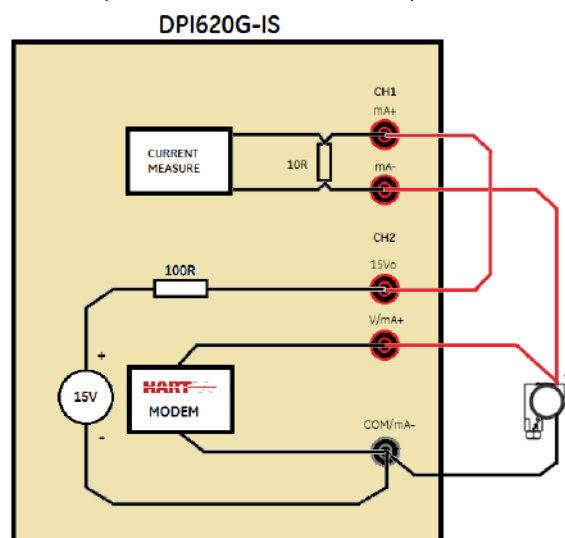

Figure 4-3 Internal Loop Power, Parallel HART Connection, CH1 Current Measure

- CH1 function is set to Current Measure
- CH2 function is set to None
- HART® function is enabled
- 250Ω resistor is Off
- Internal Loop Power is turned on through the Settings Menu for the HART® channel

A diagrammatic representation of the loop is shown in Figure 4-4.



## 5 Transmitter - Test Connection

Use the Test connection on a HART® transmitter, use CH1 to measure current and CH2 to communicate with the HART® device.

- CH2 must be set to None
- CH1 must be placed into current measure mode
- An external HART® resistor in the loop and the Internal Loop Power should be turned off.

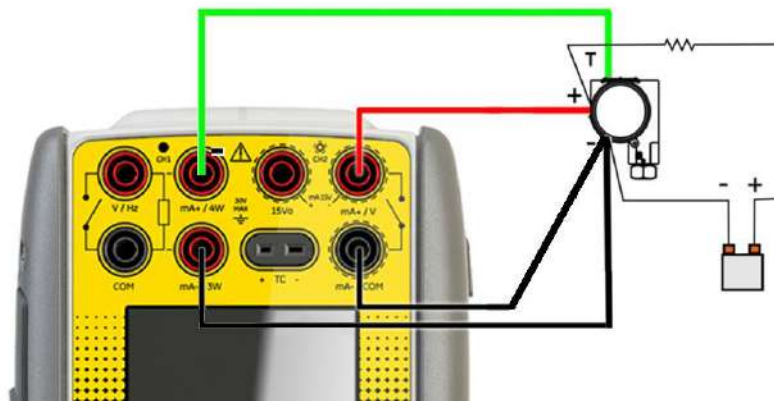

Figure 5-1 Test Connection

The test connection in the transmitter may be +ve or -ve. Figure 5-1 shows connection for a +ve Test terminal. For a -ve Test terminal the Test terminal will be connected to CH1 mA- terminal and CH1 mA+ connected to the transmitter +ve terminal.

## 6 Positioner - Internal Loop Power Supply with Current Source

In the example that follows, the internal power supply provides the loop power and the loop impedance required for the HART® function is provided by the output impedance of the internal power supply and the current sourcing circuit. This connection method should be used for all devices that are driven (and controlled) by a current source.



Figure 6-1 Positioner Connection with Internal Loop Supply

CH2 function is set to Current Source (Loop Supply), with current set to the minimum input current (typically 4mA). The HART® function is enabled and 250Ω resistor is set to off.

For these devices, it is important that the DPI620G-IS is in current source mode, acting as a controlled current source. If DPI620G-IS is in current measure, the device under test will draw the maximum current permitted by the power supply and HART communications may not be possible. To control the positioner, the source current can be set between 4 mA and 20mA.



## 7 Positioner - External Loop Supply with Current Source

In the example that follows, an external power supply provides the loop power and the loop impedance required for the HART® function is provided by the current sourcing circuit and optional internal HART resistor. This connection method should be used for all devices that are driven (and controlled) by a current source.

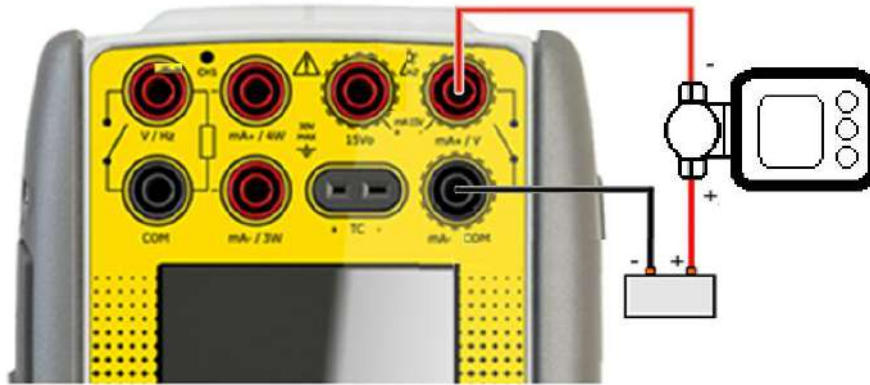

Figure 7-1 Positioner Connection with External Loop Supply

CH2 function is set to Current Source (Loop Supply), with current set to the minimum input current (typically 4mA). The HART® function is enabled and 250Ω resistor is set to on.

For these devices, it is important that the DPI620G-IS is in current source mode, acting as a controlled current source. If DPI620G-IS is in current measure, the device under test will draw the maximum current permitted by the power supply and HART communications may not be possible. To control the positioner, the source current can be set between 4 mA and 20mA.

Please let me know if I can clarify this further.

Best Regards,

**Steve Matthews** – Senior Engineer – Process Calibrators  
Measurement & Sensing - Pressure  
GE Oil & Gas  
Digital Solutions